

The Influence of a Capture Jet on the Efficiency of a Ventilated Ceiling in a Commercial Kitchen

Risto Kosonen & Panu Mustakallio

R & D Director Asia, Halton Singapore Rep. Office, 22 Leonie Hill Road #16-01
Singapore 239195

Abstract

The ventilated ceiling is a flexible solution for kitchen ventilation where heat loads are relatively low and aesthetics is a concern. By using a capture jet in the ventilated ceiling, it is possible to improve the total effectiveness of the ventilation system. This means better indoor air quality and thermal comfort. In addition, the energy consumption of a capture jet ceiling is lower than that of a traditional ceiling concept. This paper demonstrates that the supply air distribution strategy has a remarkable influence on pollution removal effectiveness and the thermal environment in kitchens. For a ventilated ceiling, the capture jet could improve the total effectiveness of the ventilation system by reducing the average contaminant level in the occupied zone by 40 %. In addition the estimated energy saving potential can be as much as 23 %.

Key words: ventilated ceiling, kitchen ventilation, capture jet

1. Introduction

Labour shortage is a big challenge in commercial restaurants. One reason for the low popularity of kitchen work is the unsatisfactory thermal conditions. In the kitchen, there are four main factors affecting thermal comfort, i.e.: air temperature, radiation, air velocity and air humidity. It is possible to influence all these factors with the air-conditioning and ventilation systems.

Ventilation and air conditioning systems are required in commercial kitchens to: (1) remove odours and particles of fat, (2) comply with hygiene requirements, (3) remove the moisture and heat that is generated from the preparation of meals and washing and (4) provide comfortable and productive working conditions. To meet these tasks, supply and exhaust air systems should be installed in the kitchen areas so that odours, air pollutants, and extra heat and moisture are removed.

Recent studies have shown that poor indoor air quality has a negative impact on thermal comfort, productivity and health issues (Wargocki 1999 and Wyon 1996). Thus, it is possible to demonstrate that an investment in an improved ventilation system is profitable through modest productivity improvements in the workplace (Hagström 2000). For example, in the USA, the average restaurant spends about \$ 2,000 yearly on salaries per seat. If productivity is reduced from 100 % to 80 % as a

consequence of poor indoor conditions, this translates to losses of about \$40,000 per annum on salaries for the owner of a one hundred seating capacity restaurant.

Published studies demonstrate quite clearly the health risk of cooking. Thiebaud (1995) indicated that the fumes generated by frying pork and beef were mutagenic. Hence, chefs are exposed to relatively high levels of airborne mutagens and carcinogens. Vainiotalo (1993) carried out measurements at eight workplaces. The survey confirmed that cooking fumes contain hazardous components. It also indicated that kitchen workers may be exposed to relatively high concentrations of airborne impurities.

Although cigarette smoking is considered to be the most important cause of lung cancer, smoking behaviour cannot fully explain the epidemiological characteristics of lung cancer among Asian women, who rarely smoke but contract lung cancer relatively often. Ng (1993) found that over 97 % of the women in Singapore do not smoke. Thus, the presumable sources of indoor air pollution for housewives are passive smoking and cooking. This study indicated that greater relative odds of respiratory symptoms were associated with the weekly frequency of gas cooking. A statistical link between chronic cough, phlegm and breathlessness on exertion was also found.

These previous studies depict the importance of well-designed ventilation in the kitchen. The efficiency of the exhaust system is especially emphasised with the ventilated ceiling system where the exhaust is located at ceiling level. The removal efficiency of the total system must be guaranteed and the spread of impurities throughout the kitchen should be prevented. The ventilated ceiling approach offers a flexible solution for kitchens where the heat loads are relatively low and aesthetics are a concern. Structurally, the system consists of a stainless steel element that covers either the entire ceiling or only the active cooking area of a kitchen. This element incorporates the air inlets, exhaust air outlets (including grease filters), and light fittings.

Ceilings are categorised as “open” and “closed” systems. In the “open ceiling”, air ductworks are connected to the voids above the ceiling. The open ceiling is usually assembled from supply and exhaust cassettes. The space between ceiling and void is used as a plenum. The more common “closed” type of plenum system comprises separate dedicated ductwork with connections to both supply and extract modules in the ceiling to avoid any risk of grease build-up in the void.

The efficiency of the exhaust system can be improved with a small capture jet installed at the ceiling surface. The air jet is projected horizontally across the ceiling, which helps to direct heat and air impurities towards the exhaust. This capture jet represents only about 10 % of the total supply air flow rate.

Although the use of hoods is ideal for handling contaminants produced in concentrated areas, the use of the air conditioning ceiling should be considered as a viable option. They are particularly suitable for the following applications (DW/171 1999):

- Structural limitations (e.g. a low ceiling level makes the use of hoods impractical);
- False ceiling aesthetics are important and visibility cannot be impaired by hoods;
- The cooking equipment does not generate intensive output in concentrated areas;
- A good level of extraction is required but the level of contaminant produced is relatively low.

In this paper, the effect of a capture jet on the efficiency of a “closed” ventilated ceiling was evaluated using CFD-simulations. This was

supported by laboratory measurements undertaken in another study (Lappeenranta 1994). The laboratory measurements were conducted with and without the capture jet in a simple one-appliance-kitchen layout. The same case-study kitchen is also simulated to obtain a more generic view of the air movement and pollutant levels in the kitchen environment. Finally, the energy saving potential of the capture jet ventilated ceiling is estimated.

2. Methodology

The effect of a capture jet on the efficiency of the ventilated ceiling was evaluated using CFD-simulations and laboratory measurements in a case-study kitchen. The laboratory measurements were carried out, in a separate study, by the Lappeenranta Regional Institute of Occupational Health (Lappeenranta 1994). Two of the cases from that study were simulated to obtain a generic view of the air movement and pollutant levels in the kitchen environment. The CFD simulations were conducted in this study using AirPak 2.0.6.

2.1 The Case-Study Kitchen

The measurements were performed in laboratory conditions with a mock-up kitchen at the Halton facilities. The ventilated ceiling is 3.5 m x 4.3 m in area and is located 2.3 m above floor level.

Figure 1 shows the ventilated ceiling concept and the four measurement points underneath the structural ceiling. The studied ventilated ceiling comprised exhaust, supply and capture jet units, with lights and ceiling elements between the exhaust and supply units. The capture jet air is supplied horizontally across the ceiling. This jet helps to direct heat and air impurities towards the exhaust.

The supply air was distributed either from both the ceiling element and capture jet unit or only from the ceiling element. In all but two cases (i.e. the two 150 % air flow cases) the kitchen space was slightly (6%) under pressurised (see: air balance in Table 1).

The kitchen appliance (size 800 mm x 800 mm x 870 mm (H)) consisted of a range with a frying pan. The surface temperature of the appliance was about 200°C with a total heat gain of 5.6 kW. The supply temperature was 18°C and the room air temperature was 22°C.

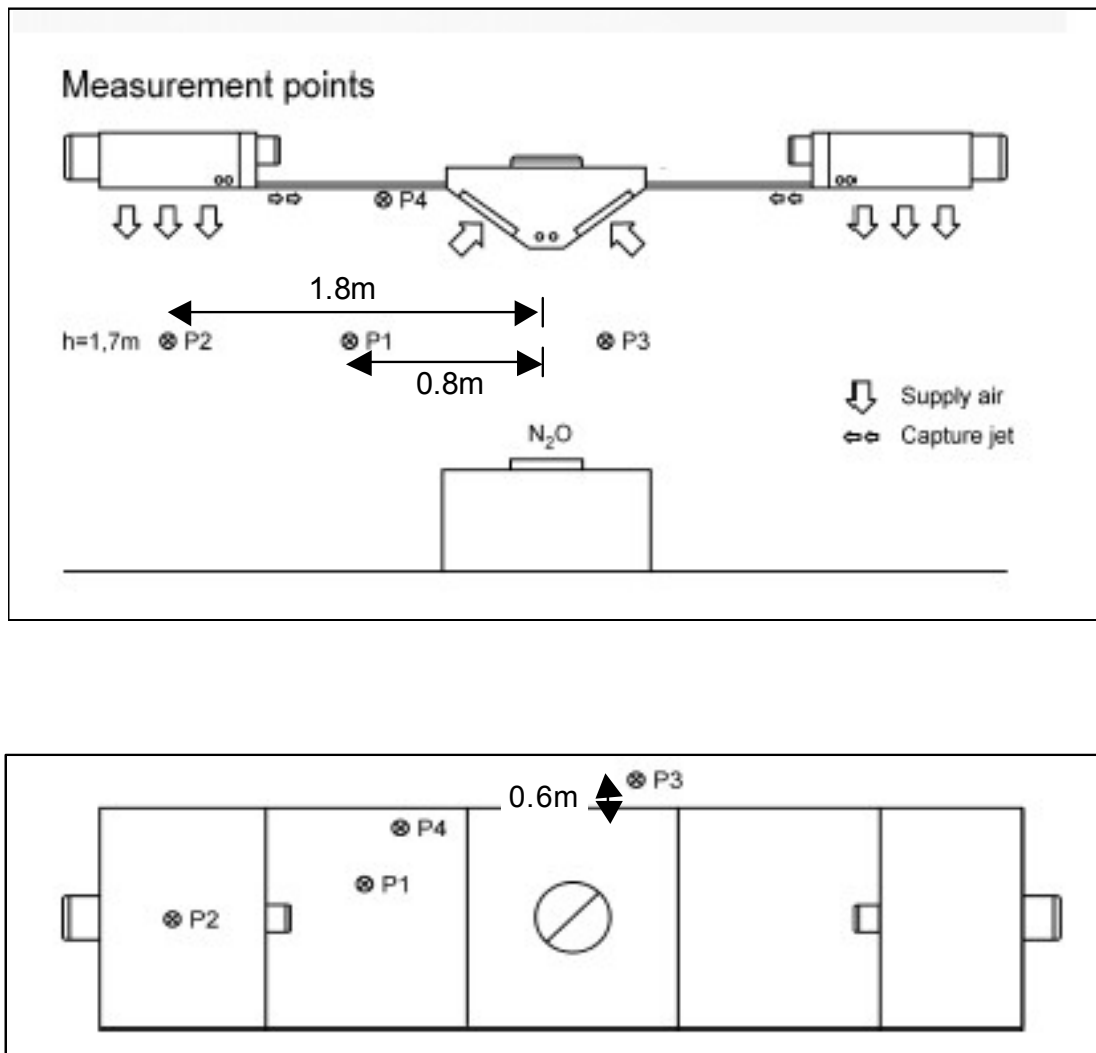

Figure 1. The layout of the mock-up kitchen with measuring locations (P1... P4).

Temperature, thermal comfort, and supply air and impurity distributions were studied in the case-study kitchen. Measurements were conducted with and without the capture jet at three different air flow rates (100 %=design value, 150 % and 50 %). Table 1 presents the studied cases

3. Results

3.1 Contaminant Measurement

Contaminant distribution was examined by releasing nitrous oxide N_2O tracer gas on the range with a constant flow rate of 210 l/h using a spiral spreader.

Table 1. The design principle and the air flow rates in the studied cases.

Design Principle	Air flow Rates (l/s) Supply+ Capture Jet / Exhaust
50 %	245+ 65 / 400 (with capture jet)
50 %	310+ 0 / 400
100 %	670+120 / 840 (with capture jet)
100 %	790+ 0 / 840
150 %	920+170 / 1090 (with capture jet)
150 %	1090+ 0 / 1090

The concentration of the tracer gas was measured at four locations in the kitchen (See Figure 1). Two sampling points were located underneath the ventilating ceiling in the occupied zone (P1 and P2 at 1.7 m level), and the third point (P3 at 1.7 m) was located outside the ventilating ceiling area. The fourth point (P4) was located near the edge of the ventilating ceiling 0.2 m from the grease extraction unit. Table 2 shows the contaminant distribution in the mock-up kitchen.

It should be noted that, at the sampling location (P1) next to the range, the concentration of the tracer gas fluctuated due to draught caused by the door opening. The values shown in Table 2 are the average values calculated without these concentration peaks.

Table 2 shows that, with the capture jet, it is possible to achieve improved indoor air quality in the occupied zone. However, in cases without the capture jet, concentrations in the occupied zone at point P1 were 2.6 times higher and at P2 were 4.7 times higher, with an air flow rate of 100 %. The concentrations with an air flow rate of 150 % were about 3 times higher.

Table 2. The measured concentrations with and without capture jet using different air flow rate values.

DESIGN CONCEPT Airflow Rate Capture Jet (on/off)	CONCENTRATION (ppm)			
	P1	P2	P3	P4
50 % (off)	89	113	66	93
50 % (on)	53	89	42	109
100 % (off)	21	47	19	20
100 % (on)	8	10	4	5
150 % (off)	19	37	12	11
150 % (on)	7	13	4	4

In the 50 %, air flow rate cases, all concentrations are high. This indicates that this air flow rate is not high enough to compensate for the induction air flow rate of the plume.

In cases without the capture jet and at 150 % air flow rate, the measured concentrations are higher than in cases with the capture jet at 100 % air flow rate. This shows that even when the exhaust air flow rate is increased by 50 %, the efficiency of the capture jet concept is still better with a much lower air flow rate. This means savings in the size of the ventilation system and improved energy economics.

3.2 The Performance of the Capture Jet

The same mock-up kitchen was simulated with an air flow rate of 100 % both with and without the capture jet.

Figures 2 and 3 show the velocity fields with and without the capture jet. In the scenario without capture jet (Figure 2), part of the plume is re-circulated back into the occupied zone. This is due the ceiling supply, which takes part of the induction air from the plume. This implies a reduction in the efficiency of the extract system.

However, the incorporation of the capture jet (Figure 3) assists the function of the exhaust unit and the plume extracts effectively without any re-circulation to the kitchen space.

Figures 4 and 5 show the temperatures in the kitchen space with and without capture jet. Figure 4 shows that, without the capture jet, part of the cold supply air moves down in the occupied zone and the temperature near the floor region is cold. This implies an increased draught risk. With the capture jet, the cold supply air stays close the ceiling level and ensures comfortable thermal conditions in the occupied zone.

Figures 6 and 7 show the contaminant levels with and without capture jet. The pollution source in the simulations was 24.7 g/s of water vapour. Figure 6 shows clearly that part of the plume is re-circulated back to the occupied zone. However when the capture jet is used, the plume rises directly to the exhaust unit.

It should be noted that the average contaminant level is much lower in the kitchen space. Only very close to the range is the pollution level high when using the capture jet.

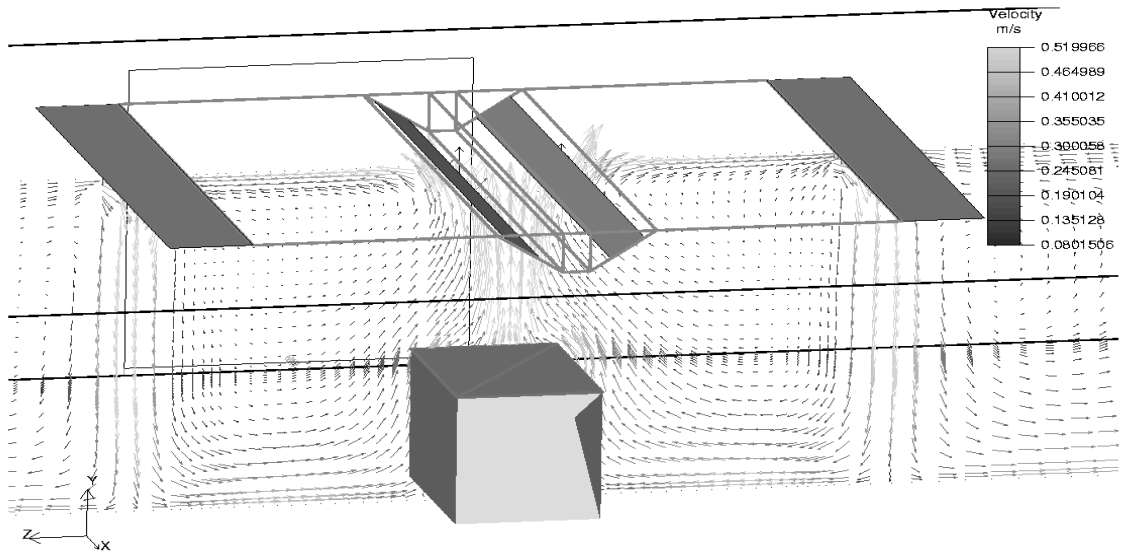

AirPak 2.0.6 Job: KCE4nc3 (KCE system with capture jets off (supply 790 at 17.7 C / exhaust 840 l/s) with 5.6 kW appliance (vapour source 24.7 g/s)); version KC

Figure 2. Velocity profile without the capture jet. The velocity vectors show that part of the plume follows the ceiling supply air flow pattern and so returns back to the occupied zone.

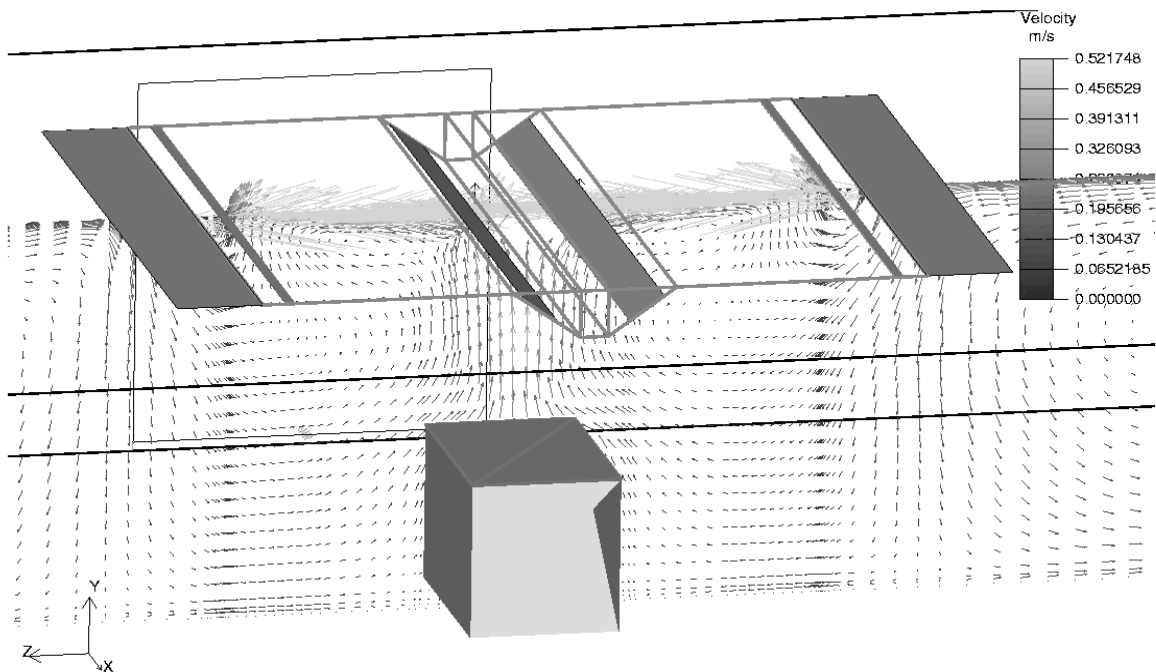

AirPak 2.0.6 Job: KCE43 (KCE system (supply 670 + 120 at 17.7 C / exhaust 840 l/s) with 5.6 kW appliance (vapour source 24.7 g/s)); version KCE4200

Figure 3. Velocity profile with the capture jet. The velocity vectors show that the capture jet pushes the plume to the exhaust unit. The plume rises up and is extracted without any re-circulation

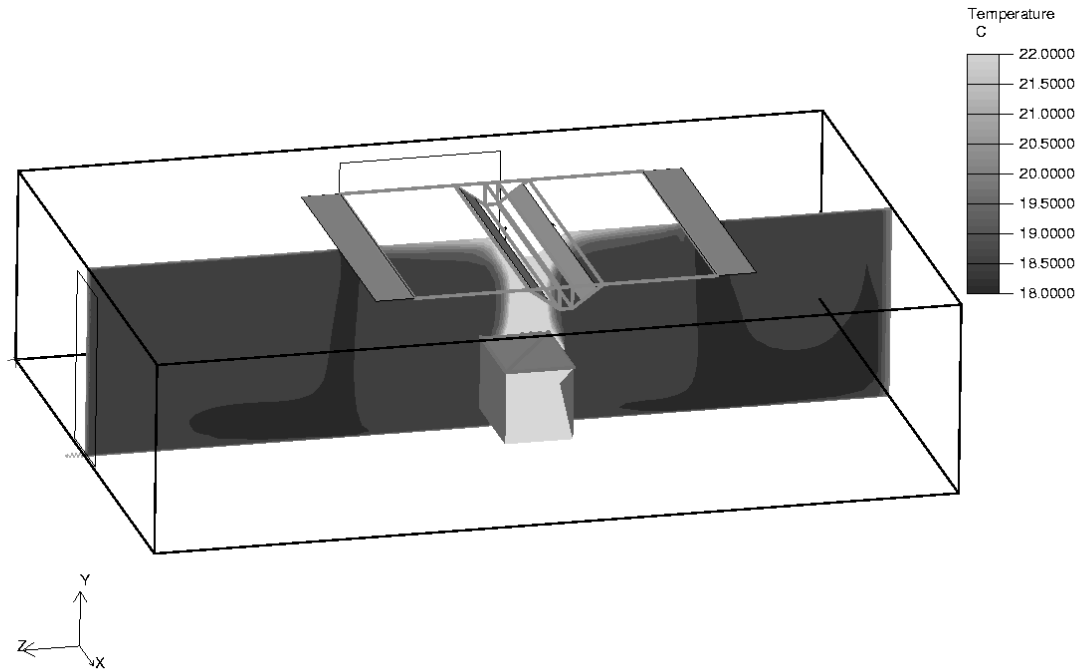

AirPak 2.0.6 Job: KCE4nc3 (KCE system with capture jets off (supply 790 at 17.7 C / exhaust 840 l/s) with 5.6 kW appliance (vapour source 24.7 g/s)); version KC

Figure 4. Temperature profiles in the kitchen space without the capture jet. A portion of the cold supply air moves downward towards the occupied and increases the draught risk.

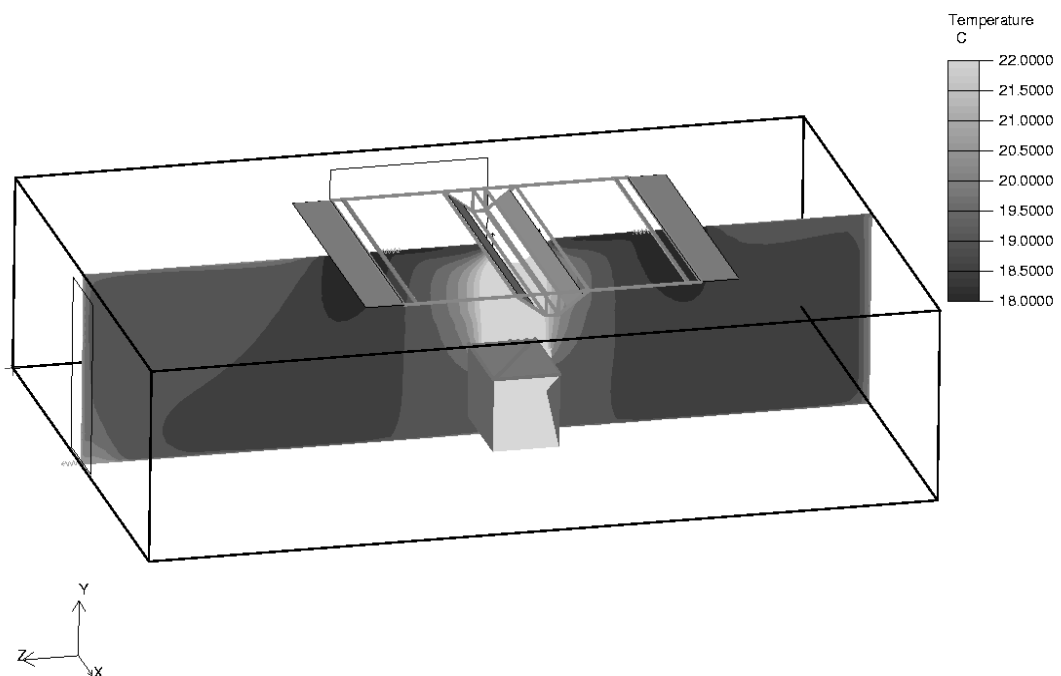

AirPak 2.0.6 Job: KCE43 (KCE system (supply 670 + 120 at 17.7 C / exhaust 840 l/s) with 5.6 kW appliance (vapour source 24.7 g/s)); version KCE4200

Figure 5. Temperature profiles in the kitchen space with the capture jet. The cold supply air remains close to the ceiling level and comfortable thermal conditions are ensured in the occupied zone.

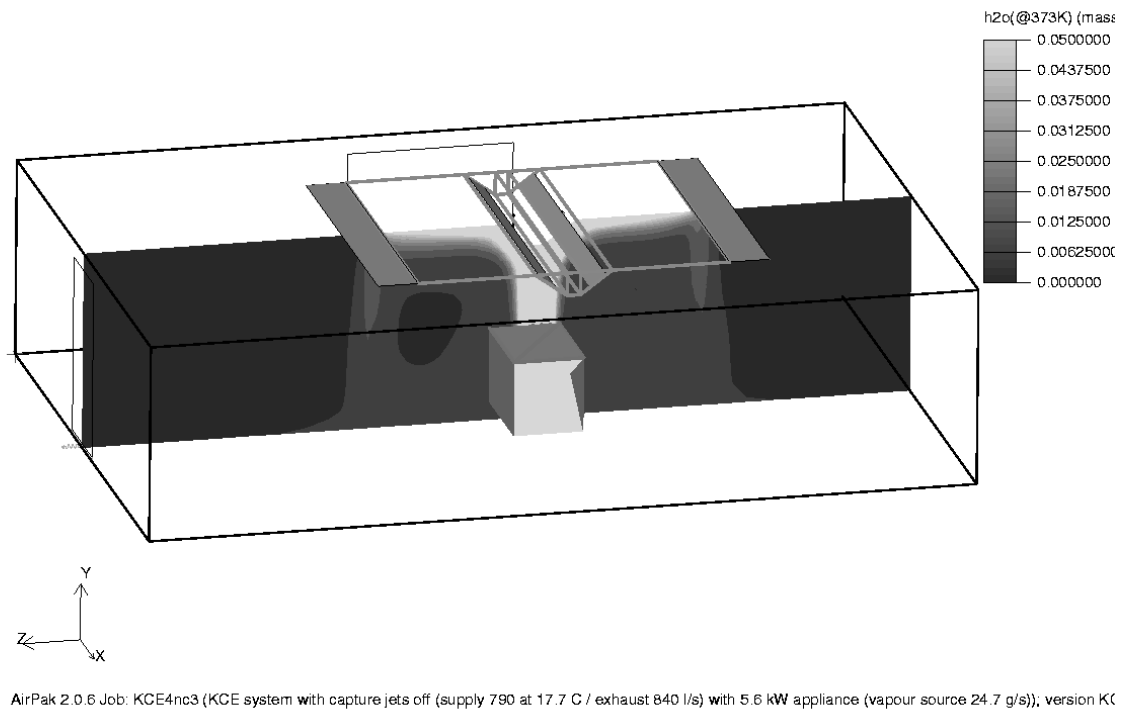

Figure 6. Contaminant level in the kitchen space without the capture jet. A portion of the plume is re-circulated back to the occupied zone

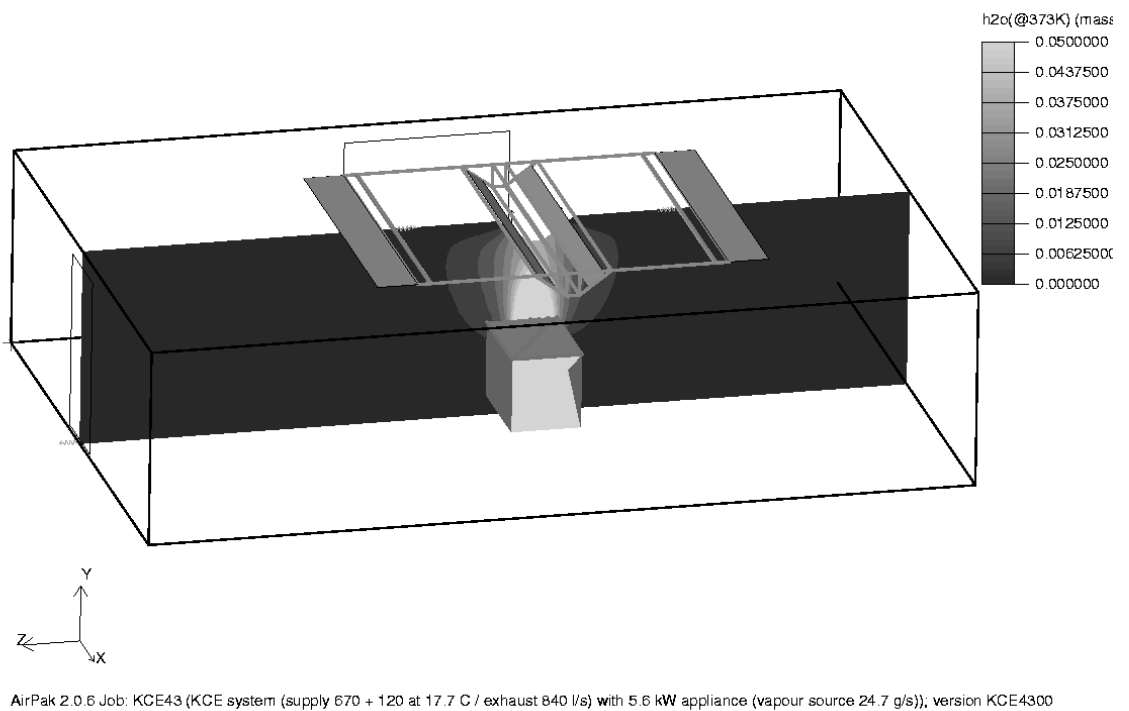

Figure 7. Contaminant level in the kitchen space with the capture jet. The plume rises nicely towards the exhaust unit.

3.3 Contaminant Study

Table 3 presents the simulated contaminant levels at the measurement points (P1-P4) with and without the capture jet. The concentrations are presented with an air flow rate of 100 %.

Table 3. The difference between simulated contaminant levels with and without the capture jet concept at 100 % air flow rate.

CFD Location	Jets on [g/g]	Jets off [g/g]	Difference to jets off case [%]
P1	0.00937938	0.00734761	28
P2	0.00143387	0.012052	- 88
P3	0.00271397	0.0044731	- 39
P4	0.00196448	0.00563153	- 65

Both the measurements (see Table 2) and the simulation give lower contaminant levels when using the capture jet. The only exception is in the simulated case at P1 where the contaminant level is higher with the capture jet. The reason for this difference was a large contamination fluctuation at P1 during the measurement period. Infiltration through the door opening (the space is under pressurised) causes turbulence.

It should be noted that location P1 is quite close to the range and the boundary of the plume. A minor change in the air movement has a significant effect upon the contaminant level. Simulation results are shown in Figures 8 and 9 where the measurement points are indicated in three sections that illustrate the contaminant levels around the measured points.

The contaminant levels with the capture jet are much lower in the occupied zone. Also, it is to be noted that the contaminant profile forms are different i.e. with the capture jet the highest contaminant levels are close to the range.

Without the capture jet, the convection flow brings part of the plume back into the occupied zone. This means that underneath the supply unit and close to the floor, the contaminant levels are quite high.

In the middle, between the range and the supply unit, the contaminant level is lower and then about the same level as with the capture jet concept.

Further from the range, the pollution level is then much higher compared to the capture jet situation.

Based on the average contaminant level in the occupied level, it is possible to obtain a more generic view of the total indoor air quality. The average value is a suitable indicator to estimate the level of the pollutant that affect the worker during hours of employment.

The average contaminants are calculated for a 4.8 m x 5.2 m x 1.8 m (H) volume. The central point of the calculated volume is the mid-point of the range. The occupied zone is divided into four different control zones in which average contaminant levels are calculated. In the calculation, the volume just over the range is not taken into account. Figure 10 shows the calculated control zones.

Table 4 presents the average contaminant levels in the four control zones and also the average contaminant level in the whole of the occupied zone. In the two control zones parallel with the range (-z and +z), the average contaminant level is about 50 % lower with the capture jet. In the two other zones (-x and +x), the average contaminant level is about 30 % lower.

Table 4. The average contaminant levels in four control zones with and without the capture jet at an air flow rate of 100 %.

Studied Volume	Jets on [g/g]	Jets off [g/g]	Difference to jets off case [%]
- Z	2.823E-03	5.597E-03	- 50
+ Z	3.011E-03	5.785E-03	- 48
- X	3.389E-03	4.940E-03	- 31
+ X	3.933E-03	5.439E-03	- 28
Average	3.289E-03	5.440E-03	- 40

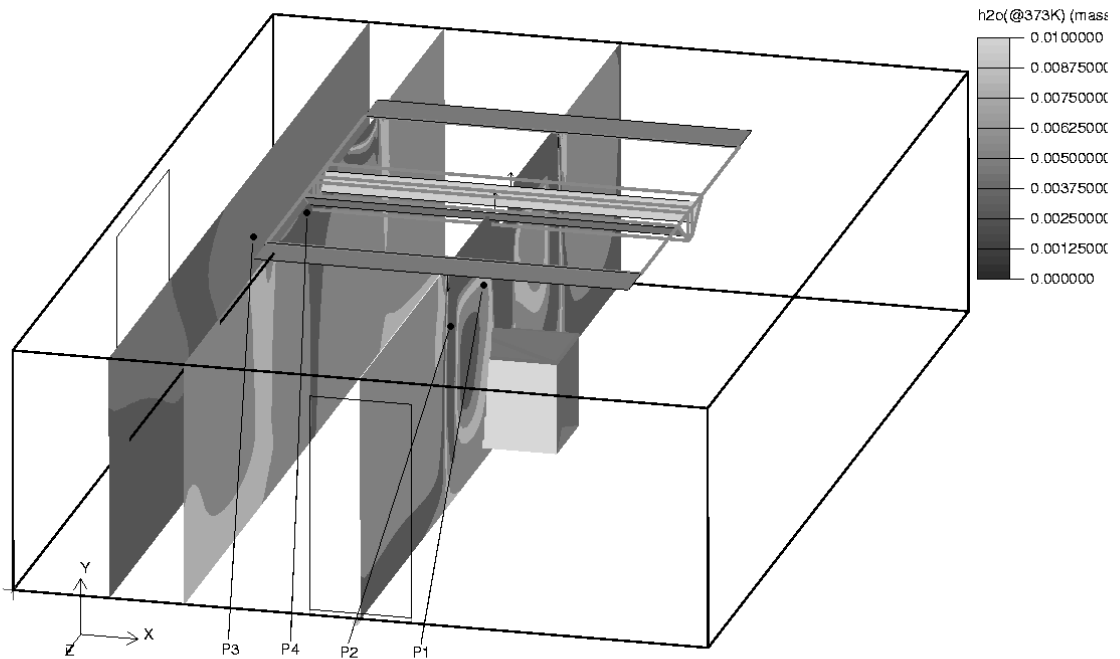

AirPak 2.0.6 Job: KCE4nc3 (KCE system with capture jets off (supply 790 at 17.7 C / exhaust 840 l/s) with 5.6 kW appliance (vapour source 24.7 g/s)); version KC

Figure 8. The simulated contaminant levels at the measurement points (P1-P4) without the capture jet in three sections.

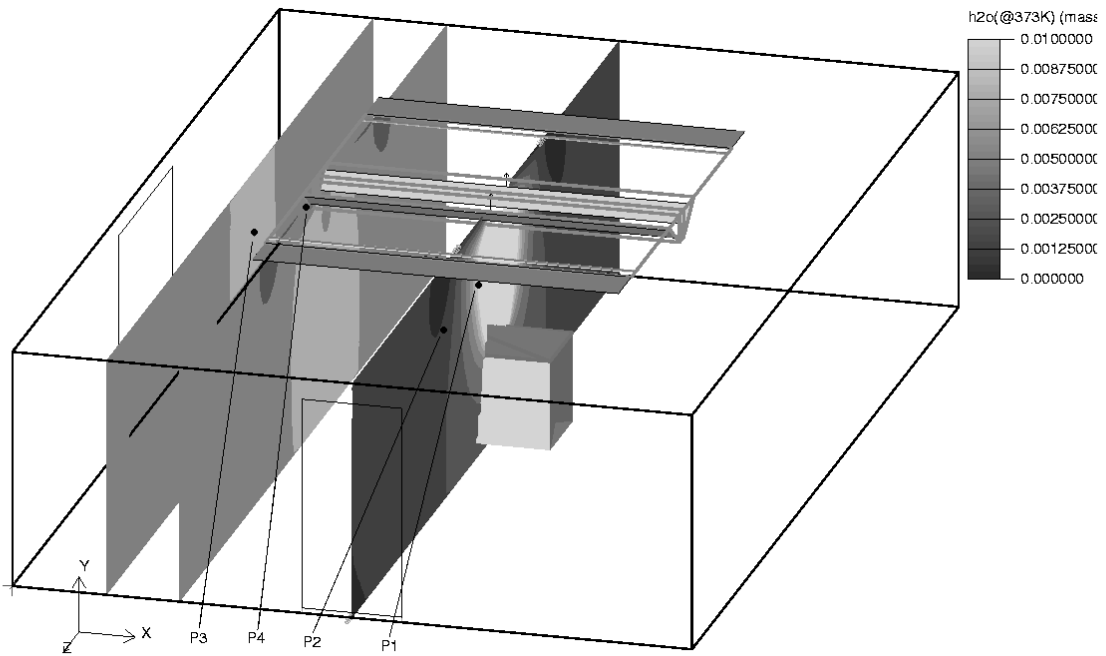

AirPak 2.0.6 Job: KCE43 (KCE system (supply 670 + 120 at 17.7 C / exhaust 840 l/s) with 5.6 kW appliance (vapour source 24.7 g/s)); version KCE4300

Figure 9. The simulated contaminant levels at the measurement points (P1-P4) with the capture jet in three sections.

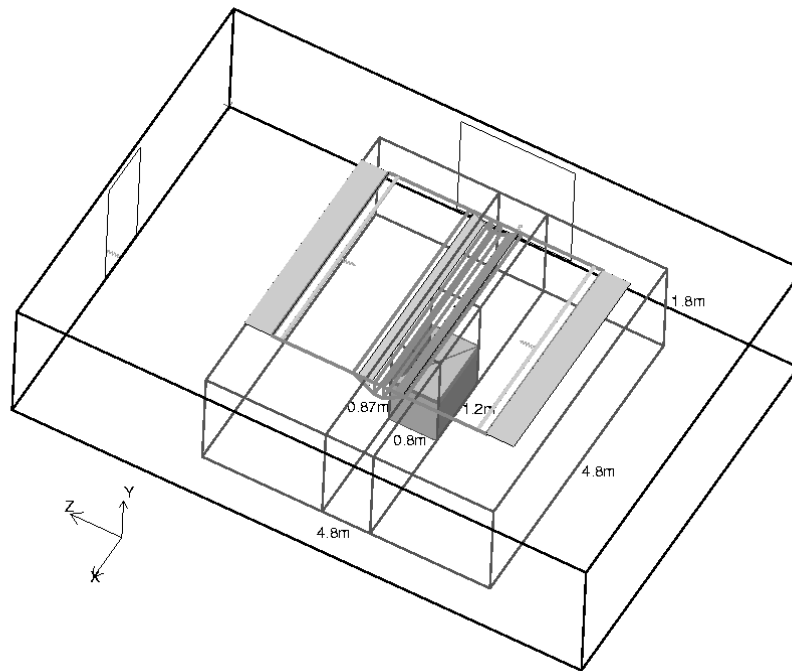

Figure 10. The calculated four control zones in the occupied zone.

Based on the simulation, it is possible to reach significant improvement in indoor air quality with the capture jet. The average contaminant level in the whole of the occupied zone is 40 % lower with the capture jet concept.

3.4 Energy Saving Potential

In the design process, the main idea is to reach the adjusted target value of indoor air quality. Energy consumption is strongly dependent on that set indoor air quality target. Thus energy consumption and contaminant level are not separate things; they should always be analysed at the same time.

With the capture jet concept, it is possible to reach a much lower contaminant level. Even if the exhaust air flow rate without the capture jet is increased by 50%, it is not possible to reach the same contaminant level as that achieved with the capture jet (see Table 2). This adjusted indoor air quality target approach means that with the capture jet it is possible to reach a greater than 50% saving in energy consumption.

If the target contaminant level is based on 100% air flow without the use of the capture jet then it is possible to determine by how much the exhaust air

flow rate can be reduced by introducing the capture jet to reach the same contaminant level.

At 100% air flow without the capture jet, the contaminant levels were 21 ppm at P1 and 47 ppm at P2. With the capture jet, and with air flow rates of 100% and 50%, the contaminant levels at P1 were 8 and 53 ppm respectively and at P2 they were 10 and 89 ppm respectively (see Table 2).

If we assumed that there is a linear correlation between air flow rate and contaminant level, the required air flow rates to reach the set targets are 85 % at P1 and 77 % at P2. This means the energy saving is between 15 and 23 %.

4. Discussion and Conclusions

Large amounts of heat, moisture and effluent are released during the cooking process. These emissions may create uncomfortable environments for kitchen workers. The main purposes of kitchen ventilation are to prevent the dispersion of effluents from the cooking process into the surroundings and to achieve satisfactory thermal conditions by capturing the excess heat that is generated during cooking.

The ventilated ceiling is a possible solution for kitchen ventilation where heat loads are relatively low and aesthetics are a concern. The ventilated ceiling is a good ventilation solution for food service facilities like schools and hospitals.

The use of hoods is an ideal solution for locally handling contaminants produced in concentrated areas. Thus, special attention should be taken with the ventilated ceiling, which removes exhaust air at ceiling level. In the worst case, the supply air flow pattern may spread heat and impurities around the working area of the kitchen.

The ventilated ceiling comprises exhaust, supply and capture jet units, lights and structural ceiling elements between the exhaust and the supply units. Capture jet air is projected horizontally across the ceiling. This jet helps to direct heat and air impurities towards the exhaust making use of a push-pull ventilation strategy.

CFD-simulations and previous measurements have demonstrated that the capture jet could help to improve the total effectiveness of the ventilation system. At the same time, indoor air quality, thermal comfort and energy efficiency are enhanced

The supply air distribution strategy has a marked influence on pollution removal effectiveness and thermal conditions. The simulations indicate that, without the capture jet, part of the plume is re-circulated back into the occupied zone. This means that a higher contaminant level is encountered and that part of the cold supply air flow rate settles in the occupied zone and increases the risk of draughts. In the scenario without the capture jet, the measured concentrations were 2.6-4.7 higher in the occupied zone. With the capture jet, the simulated average contaminant level in the whole of the occupied zone was 40 % lower. The estimated energy saving potential is 15 – 23 %.

Based on this study, the capture efficiency is not improved after a certain level of exhaust air flow rate, even if flow rates are increased. Therefore, the main point is to optimise the requested exhaust air flow rate and to adjust it for the existing convective load of kitchen appliances. The amount of air carried in a convective plume should be theoretically calculated and adjusted by matching the exhaust air flow rate.

However, there is no standard methodology for exhaust air flow calculation and any capable

definition for the capture efficiency with ventilated ceilings. A more accurate design method should be developed in the future.

Acknowledgements

The study is supported by Technology Agency of Finland (TEKES). The authors wish to thank to Drs David Cheong and Freddie Tan for their comments.

References

- DW/171 (1999) "Standard for kitchen ventilation systems." Heating and Ventilation Contractors Association, London
- Hagström K; Kosonen R; Heinonen J and Laine T. (2000) "Economic value of high quality indoor air quality." Proceedings of Healthy Building 2000 Conference, August 6-10, Espoo.
- Lappeenranta Regional Institute of Occupational Health (1994). "Ventilation performance in a pilot kitchen with the integrated ventilating ceiling KCE." Report 94014 F.
- Ng TP, Hui KP and Tan WC. (1993) "Respiratory symptoms and lung function effects of domestic exposure to tobacco smoke and cooking by gas in non-smoking women in Singapore", *Journal of Epidemiology and Community Health*, **47**, Issue 6, pp 454-458
- Thiebaut HP, Knize MG, Kuzmicky PA, Hsieh DP and Felton JS. (1995). "Airborne mutagens produced by frying beef, pork and a soy-based food", *Food and Chemical Toxicology*, **33**, Issue 10, pp 821-828
- Vainiotalo, Sinikka; Matveinen, and Katri (1993), "Cooking fumes as a hygienic problem in the food and catering industries", *American Industrial Hygiene Association Journal*, **54**, Issue 7, pp 376-382
- Wargoocki P, Wyon DP, Baik YK, Clausen G, and Fanger PO. (1999). "Perceived air quality, SBS-symptoms and productivity in an office at two pollution loads". The 8th International Conference on Indoor Air Quality and Climate, Edinburgh, Scotland.
- Wyon DP. (1996). "Individual microclimate control: required range, probable benefits and current feasibility". Proceedings of Indoor Air '96, Institute of Public Health, Tokyo.

