

UPT-W, UPT-I

Unipoint

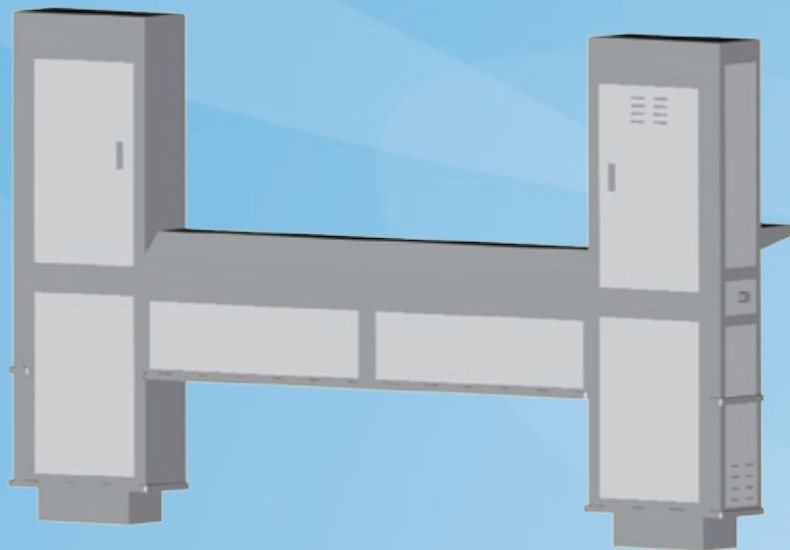

60/UPT-W,UPT-I/250/0106/EN

Custom made. Full range of models. Internal services included.

- Custom made to suit each application
- Available as either a wall-type unit (UPT-W) or Island type (UPT-I)
- All internal pipework and technical services pre-assembled and tested off site. Fabrication only, can be provided if required.
- Co-ordinated interface with ventilation products
- Fully accessible for easy cleaning and maintenance
- Total segregation of M & E services
- A wide range of optional extras
- More versatility and serviceability than conventional methods
- 'Inbuilt' flexibility allowing ease of additions/changes
- Dedicated and or multi-serviced risers to suit each application

Application

Developed for the use in commercial kitchens, the Unipoint range of S.D U's provides an efficient and economical layout. Pre-assembled off site with all internal services, the Unipoint eliminates the co-ordination of other trades allowing minimal preparatory work in bringing mains services to a 'single point' of connection for final 'hook up'.

Consultant Specification

Services Distribution Unit Model Unipoint _____ having overall dimensions of _____ x 300 x 1250/ height to suit ventilation canopy/false or ventilated ceiling (Delete as required) Unit manufactured from 1.2mm thick (18g) stainless steel, fully formed, folded and welded construction.

Unit comprising:

Electrical riser complete with range of rotary type isolators and electrical distribution board (Delete as required)

Mechanical riser - complete with side hinged door for access to valved services.

Combined Elec/mech riser complete with range of rotary type isolators and electrical distribution board (Delete as required) and side hinged door for access

to valved services. Services to be fully segregated throughout.

Horizontal Raceway complete with lift off access panels (mechanical section) and conceal fixed removable sloping profile lid (elec section) Services fully segregated with all services being mechanically sealed.

Total assembly mounted on telescopic plinths to accommodate floor conditions.

Unit to be fitted out with range of services to suit cooking equipment layout terminating on the underside of the horizontal raceway with 1/4 turn isolating valves and or waterproof plug and socket sets. All services to be designed and installed to latest codes/regulations. Refer to 'Modifications & Options' for full listing of available optional extras.

Modifications & Options

- Incorporation of integrated Water Wash Control Panel
- Incorporation of integrated Ecology Unit Control Panel
- Incorporation of integrated Fire Suppression Control Panel
- Incorporation of integrated Electrical Distribution Panel
- Gas Solenoid Valve
- Fuel Shut off Facility
- Cantilever Shelf Supports for High Level Equipment
- Ventilation Canopy Lighting Control
- Catering Equipment Flexible Hoses/quick release assemblies
- Water Taps
- 2 - level Bumper rails
- Combined electrical/mechanical risers
- General Purpose Switched Socket outlets

Services Options

Electric

Gas

Cold Water

Hot Water (flow & return)

Steam

Condensate

Model UPT-W - wall type

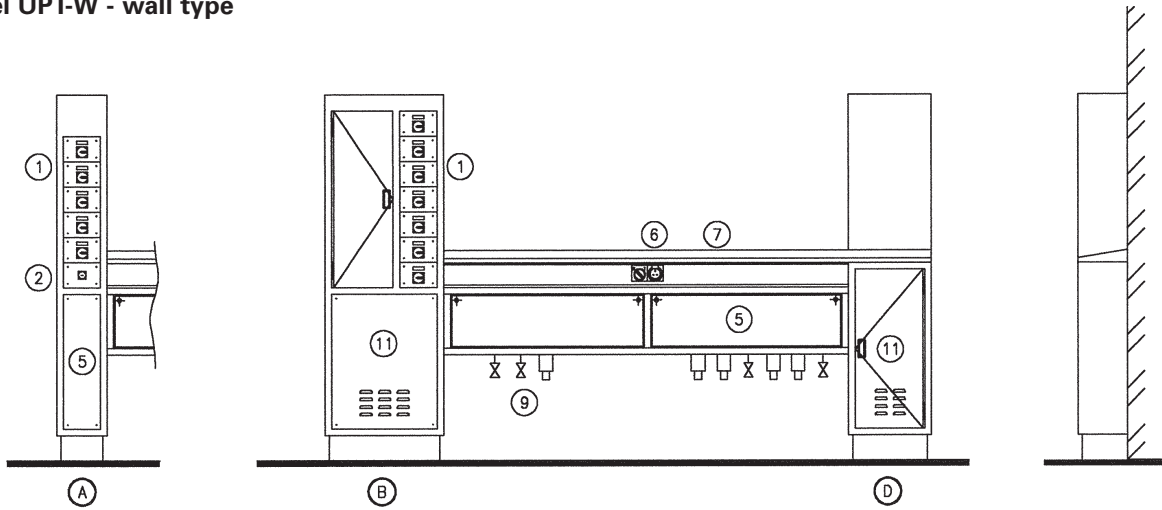

Model UPT-I - island type

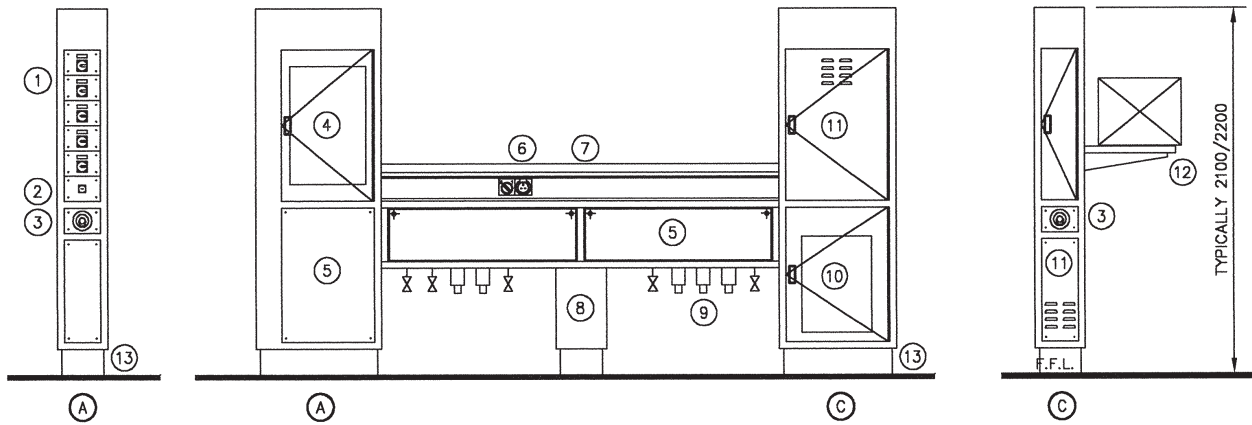

Unipoint Options

- | | |
|---|--|
| 1. Rotary Isolators | 10. Fire Suppression System (optional) |
| 2. Emergency Fuel Shut off (optional) | 11. Ventilated Access Panels/Doors |
| 3. Fire Suppression System (optional) | 12. Cantilever Equipment Supports |
| 4. Electrical Distribution Board (optional) | 13. Telescopic Plinths |
| 5. Access Panels/Doors | |
| 6. Switched Socket Outlets (optional) | A. High Level Electrical Riser |
| 7. Conceal Fixed Sloping Lid | B. High Level Combined Elec/Mech Riser |
| 8. Pedestal Leg | C. High Level Mechanical Riser |
| 9. Outgoing Services (refer for options) | D. Low Level Mechanical Riser |

The company has a policy of continuous product development, therefore we reserve the right to modify

design and specifications without notice. Unipoint is a registered trademark of Halton Vent Master Ltd.

UPT-W, UPT-I - Unipoint

Halton Vent Master

Halton Vent Master Ltd, 11 Laker Road, Airport
Industrial Estate, Rochester, Kent ME1 3QX U.K.
Tel. +44 (0) 1634 666 111, Fax +44 (0) 1634 666 333